

AS-Interface Standard Cabinet module for actuators and indicators. Connect with standard cable of your choice. It can be parameterized to different indicator colors and functions.

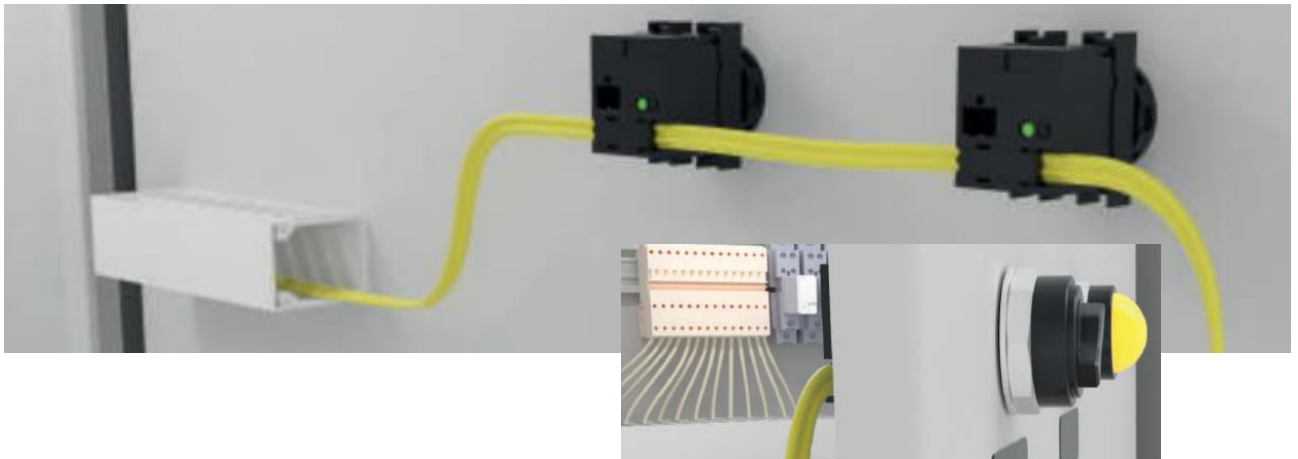

Cabinet Module Characteristics

- Replaces contact block and fit your favorite selector and key switch, 2 and 3 position, pushbuttons and/or use as a lamp, see www.celpia.com for a complete list of supported devices
- Easy tool free installation and connection using a AS-Interface standard cable “cabinet cable”
- Compact module size
- One module for all Actuator & Indicator you use
- Monitoring and troubleshooting available for actuators and indicators
- By using AS-Interface technology, diagnosis and fault monitoring is possible at operator control point
- LED-lamp with 6 colors: Red, Green, Yellow, Amber, Blue and White
- The LED-lamp can be configured in 8 different indication modes
 - Continuously ON at High intensity
 - Continuously ON at Low intensity
 - Flash On/Off at Low speed
 - Flash On/Off at Normal speed
 - Toggle between High/Low brightness at Low speed
 - Toggle between High/Low brightness at Normal speed
 - Fade between Off-High-Off intensity at Low speed
 - Fade between Off-High-Off intensity at Normal speed
- Up to 62 slaves can be connected to one single AS-Interface cable



Preamble

This document will provide detailed information of how to install and configure the AS-Interface Cabinet module CMSTD.

General safety instructions

The following precautions must be observed to ensure safe operation.

1. Do not use the product in environments subject to flammable or explosive gases.
2. The product must only be used indoor or inside a cabinet or box with proper protection class.
3. Do not attempt to disassemble, repair, or modify the product.
4. Do not use a voltage that exceeds the rated operating voltage range.
5. Dispose of the product according to applicable regulations (laws).

Intended Use

The product is designed and intended for specific purpose as described. The product may only be used with equipment and under operating conditions described in relevant documentation. Users must be qualified to handle the devices and be aware of the hazards potentially associated with the process. The user is solely responsible for applications, which go beyond the intended use described here and for each individual product or equipment or device, which are not described in instructions sets.

Misuse of the product

Read this document carefully and always follow all instructions. Celpia AB assumes no responsibility for any damage caused by not following the instructions in this, and product-related documents. Any use beyond the intended use is considered to be misuse.

Exclusion of liability

The information contained herein is accurate at the time of publication, subject to editorial errors. Compatibility with future versions of this product is not guaranteed.

Certification

In order to ensure that all Celpia's AS-Interface products meet the applicable requirements for reliable function and failure immunity, they have been tested by an independent authorized laboratory and have the AS-Interface Certification Logo printed on it.

The products have been tested by an authorized laboratory and meet the applicable EMC requirements.

Technical data

Type of voltage supply for power supply	Using AS-Interface, Standard and Power24
Operating voltage	16.5 – 31.6V DC
Max total current (18 – 31.6V DC)	30mA
Electrical connection of the AS-Interface line	Plug-in terminal as piercing terminal for AS-Interface cabinet cable 2x0.86 VZN FRNC / 802183 and Mail connector for 2 way plug, Phoenix MSTB2,5 (refer to the accessories)
AS Interface Connection Polarity reversal protection	Built-in
Addressing	Programmable via Power Barrel Connector, Outer diameter 3.40mm, inner diameter 1.30mm or AS-Interface connector
Slave profile	S-7.A.E Extended ID Code 1 is set to 7 by default but can be changed by user
AS-Interface version	3.1
Display of AS-Interface status	Green and Red LED
Inputs / Actuator switches	2
Outputs / LED-lamp indicator colors	Red, Green, Yellow, Amber, Blue, White
Dimensions	Width 29mm, Height 31mm, Depth 30mm
Ambient temperature during operation	-25...+60°C
Ambient temperature during storage	-40...+60°C
Protection class	IP 20
Certificates/approvals	CE marking EN 62026-2:2013/A1:2019 RoHS 2011/65/EU WEEE 2012/19/EU
Delivery note	The modules are delivered without the plug Phoenix MSTB2,5
Ordering information	CMSTD

Mounting instructions

The Cabinet module is mounted on the back of a switch or a lamp in the same way the contact block or lamp block is mounted. Simply snap the module on the back of the desired device. See www.celpia.com and manufacturer of switch or lamp for further instructions.

Connection of Cabinet module

The Cabinet Module can be connected in three different ways. First and preferably by using a standard AS-Interface cabinet cable, secondary with color coded hook-up cables or third by connecting both.

AS-Interface cabinet cable

If a standard AS-Interface cabinet cable is used, no tools are needed. Remove the wedge and place the cable in the groove that is designed so that the cable fits when properly polarized. Reinstall the wedge and push it in manually, the piercing pins will penetrate the cable insulation.

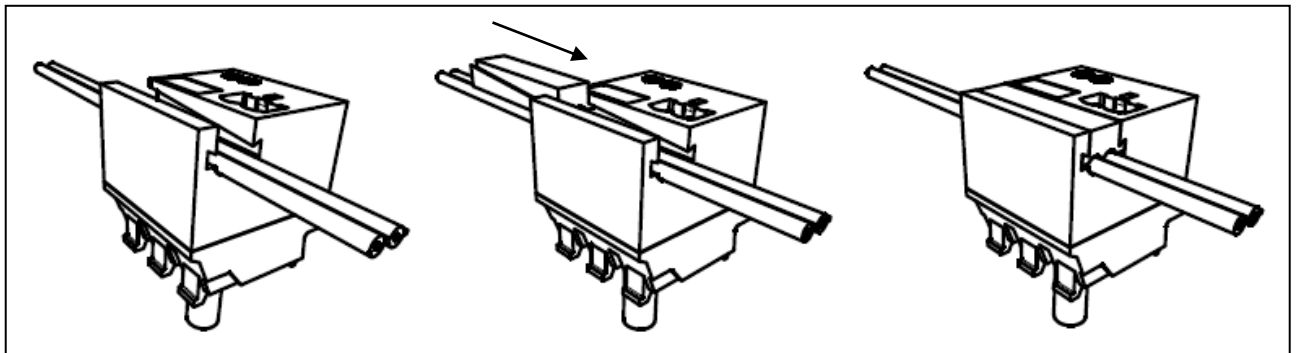

Hook-up wires

If hook-up wires are used, a 2 way plug is needed (see chapter accessories).

- Single conductor size:
 - 0,75 – 2,5 mm² (AWG 18 – 12)
- Color coding:
 - Brown ASI+
 - Blue ASI-

AS-Interface cabinet cable and hook-up wires

It is also possible to connect a Cabinet module with both hook-up wire and AS-Interface Cabinet cable and then link to a desired number of Cabinet modules with the Cabinet cable.

Note! If the AS-Interface link will continue to other devices, make sure not to reduce the cable area.

Semantics of I/O data bits and parameter settings

Output from master to cabinet module slave.

Bit D2-D0: Value	LED color
0 (0000 _{Bin})	OFF
1 (0001 _{Bin})	Red
2 (0010 _{Bin})	Green
3 (0011 _{Bin})	Blue
4 (0100 _{Bin})	Yellow
5 (0101 _{Bin})	Amber
6 (0110 _{Bin})	White
7 (0111 _{Bin})	OFF

Data bits to select LED color

Parameter value	Light effect
0 (0000 _{Bin})	Fixed ON with normal brightness
1 (0001 _{Bin})	Fixed ON with low brightness
2 (0010 _{Bin})	Slow flashing indication, ON/OFF, 0,5 Hz
3 (0011 _{Bin})	Normal flashing indication, ON/OFF, 2 Hz
4 (0100 _{Bin})	Slow flashing indication, HI/LO intensity, 0,5 Hz
5 (0101 _{Bin})	Normal flashing indication, HI/LO intensity, 2 Hz
6 (0110 _{Bin})	Slow fading indication, 0,5 Hz
7 (0111 _{Bin})	Normal fading indication, 2 Hz

Parameter settings to control LED-lamp light effect

Input when master read cabinet module slave.

Data bits				Switch status	
D3	D2	D1	D0	SW 2	SW 1
0	0	0	1		X
0	0	1	0	X	
0	0	1	1	X	X

X = Activated Switch

Dimensions

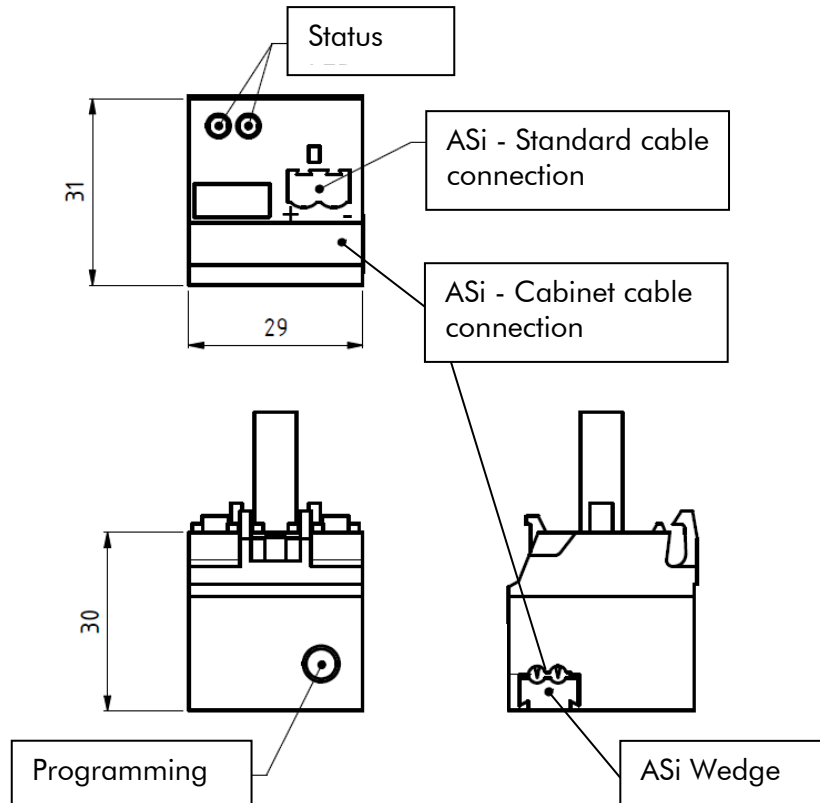



Accessories

Component	Order number
2 way plug, Phoenix MSTB2,5	See www.celpia.com
ASi Wedge	See www.celpia.com
Cabinet cable 2x0.86 VZN FRNC / 802183	See www.celpia.com

Supported devices

See www.celpia.com to for details.

Dismantling and disposal

EU Waste Electrical and Electronic Equipment (WEEE) Directive

In August of 2005, the European Union (EU) implemented the EU WEEE Directive 2002/96/EC and later the WEEE Recast Directive 2012/19/EU requiring Producers of electronic and electrical equipment (EEE) to manage and finance the collection, reuse, recycling and to appropriately treat WEEE that the Producer places on the EU market after August 13, 2005. The goal of this directive is to minimize the volume of electrical and electronic waste disposal and to encourage reuse and recycling at the end of life.

Celpia AB has met its national obligations to the EU WEEE Directive by registering in those countries to which Celpia AB is an importer. Celpia AB has also elected to join WEEE Compliance Schemes in some countries to help manage customer returns at end-of-life.

If you have purchased Celpia-branded electrical or electronic products in the EU and are intending to discard these products at the end of their useful life, please do not dispose of them with your other household or municipal waste. Celpia AB has labeled its branded electronic products with the WEEE Symbol (figure 1) to alert our customers that products bearing this label should not be disposed of in a landfill or with municipal or household waste in the EU. Instead, please be aware that Celpia AB is making a return and collection system available to you, free of transportation and recycling costs, for discarding these products.



*Figure 1 WEEE symbol -
crossed out wheeled bin*



Revision history

Revision	Description
0	First release